

CM2 SIDESCAN SONAR, WING DEPRESSOR SPECIFICATION

Issue 3, March '11

1. GENERAL

The CM2 wing depressor is designed to be easily attached and removed from a CM2 towfish . It increases the towfish depth for any specific tow cable length and tow speed. It consists of the wing and the tail unit, the wing providing hydrodynamic down force and the tail providing stability.



[Note: the design of the CM2 towfish allows a high-aspect-ratio wing to be positioned below the tow point without obstructing the acoustics. This wing and tail combination is significantly more efficient and stable than top-mounted delta-fin depressors.]

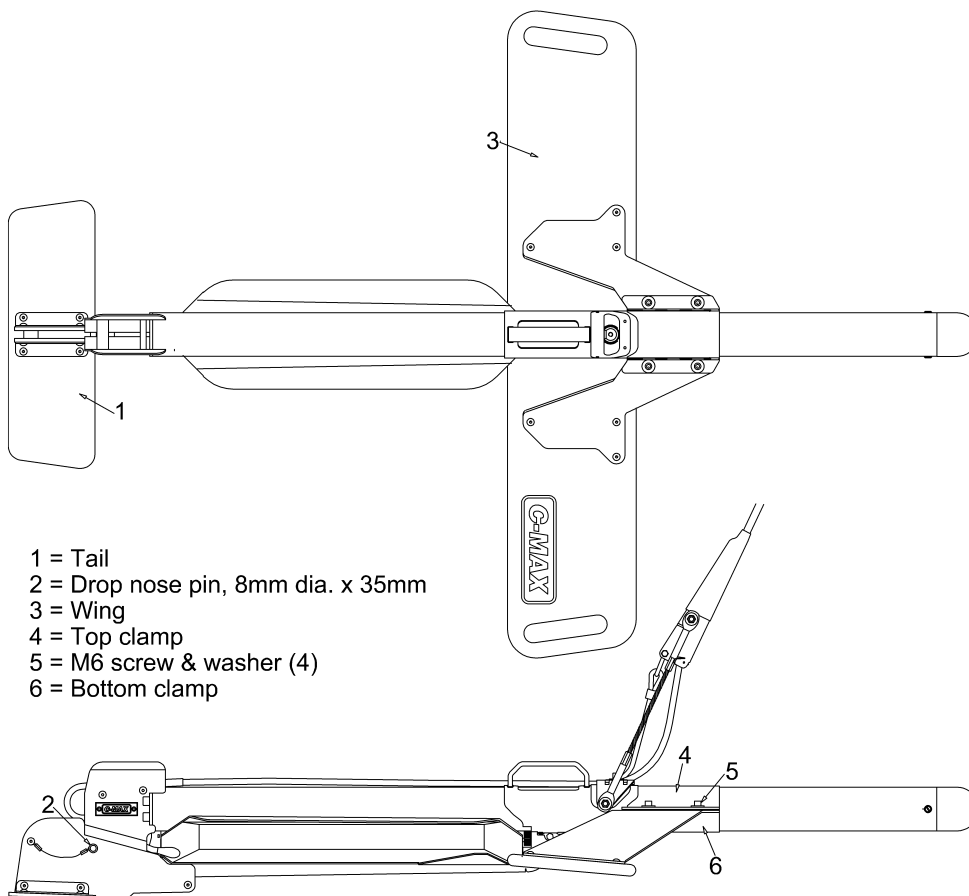

2. MECHANICAL

Construction

stainless steel and Nylon-66

Wing span

0.892m

Weight (wing plus tail)

5.1kg in air, 2.0kg in water

3. PERFORMANCE

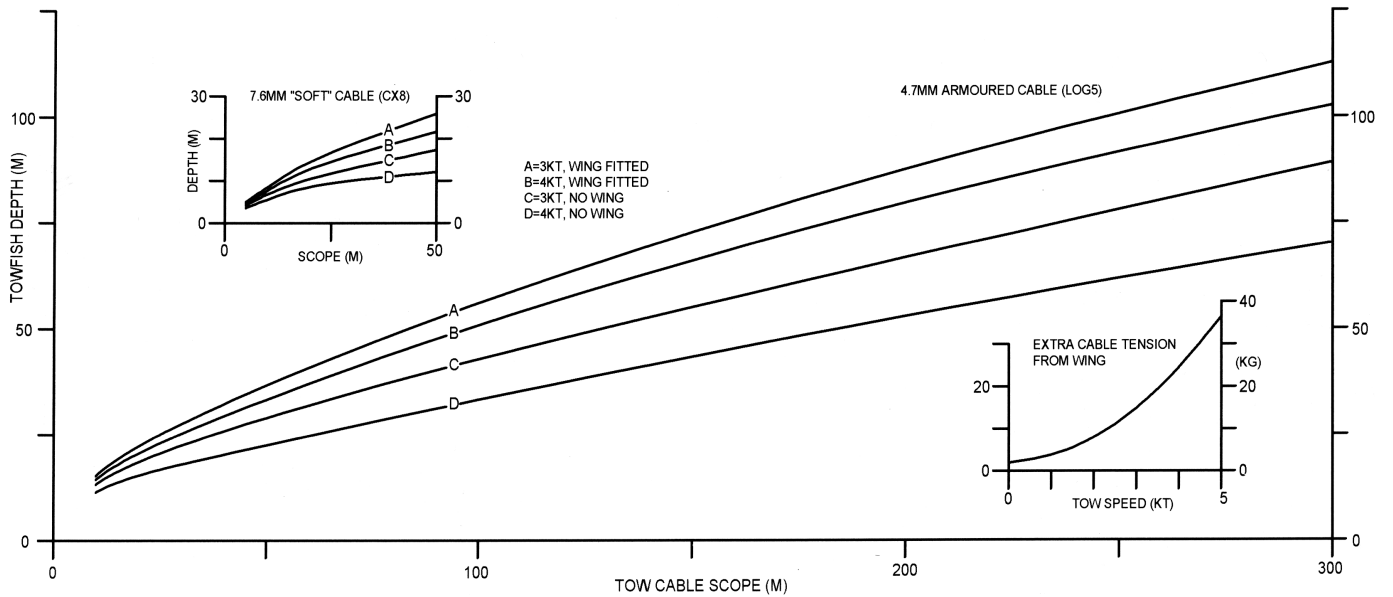

The above specification may be changed without notice.

C-MAX Ltd, 9 Hybris Business Park, Crossways, Dorchester, Dorset DT2 8BF, U.K.

Tel: +44 1305 853005, fax: +44 1305 852136, email: sales@cmasonar.com, web: cmasonar.com